



The SpacePath Communications 20W-65W BUC / SSPB / SSPA powered by GaN technology super compact series are *revolutionary in size, weight and power density*. This series offers superior performance in an extremely compact package that can fit in your palm! Weighing at only 2KG, our feature-rich GaN unit is exceptionally powerful for its size: up to 65W Psat.

SpacePath Communications GaN super compact features best in class RF characteristics, embedded WG circulator, extensive monitor and control capabilities enabled via Ethernet, Serial and/or Analog Interfaces. This series remarkably small size and low power consumption results in better heat extraction that leads to overall system size and cost reduction making it the ideal candidate for portable, mobile and VSAT on the move applications. Its small size and weight allows direct feed horn mounting, which makes it a most economical solution for fixed VSAT applications

Options

- Internal / Autosense 10Mhz reference
- True RMS detector
- Antenna Mounting kit

Features

- Up to 65W PSAT Output Power in this super-compact light weight package 14x15x9.5cmm
- Only 290W power consumption at 60W output
- 200W power consumption at 3dB back of
- Switchable LO - Standard and Extended Ku-Band in one unit
- RF overdrive protection
- Status LED

- Superior RF performance:
 - Phase noise 6dB better than IESS308/309
 - High Linearity
 - Spurious below -60dBc
 - Wide dynamic range of Gain Control
- Built in WG Circulator provides full output VSWR Protection
- Configuration via RS-232 serial console, packet protocol RS-485 and User friendly Ethernet HTTP based GUI and SNMP support
- Redundancy Ready - No external redundancy controller required
- Field Replaceable Fans
- Field upgradable software

Outline

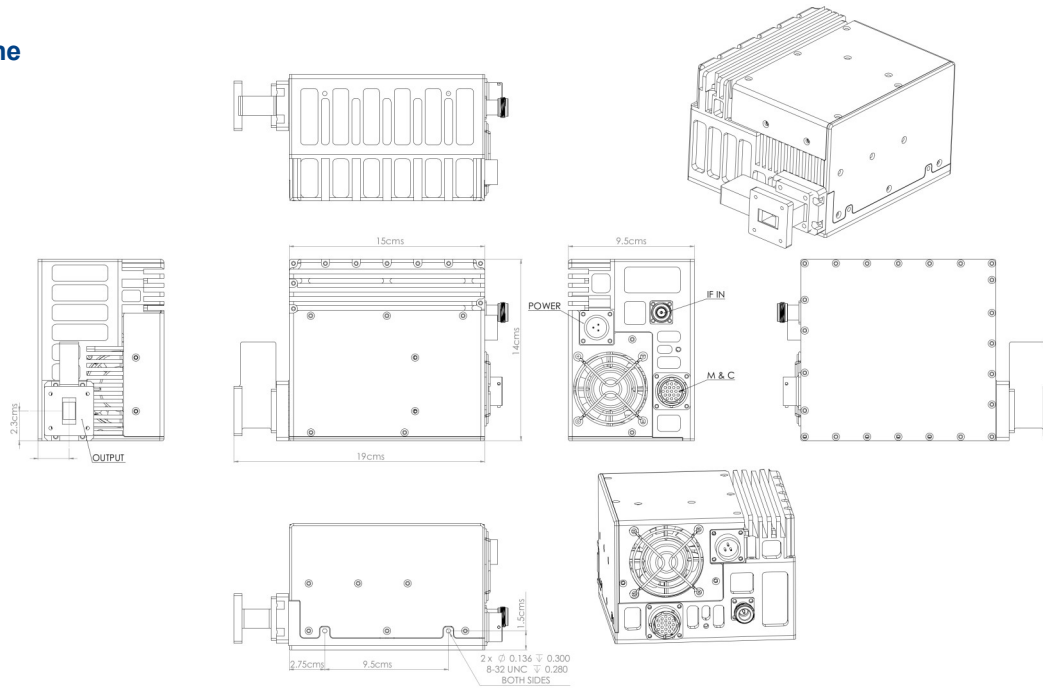

20-65W L- to Ku-Band Block-Up –Converter Specification

Parameter	20W	40W	50W	65W
RF Performance				
RF Frequency Range-Available in/switched		14-14.5GHz	13.75-14.5GHz	
IF Frequency Range		950-1450MHz	950-1700MHz	
LO Frequency (Switchable)		13.05GHz	12.8GHz	
Conversion	Single Conversion; non-inverting			
Saturated Power	43dBm typ	46dBm typ	47dBm typ	48dBm typ
Linear Power	40dBm min	43dBm min	44dBm min	45dBm min
Conversion Gain	72dB min, 75dB typ			
Gain Flatness	+/-1dB typ +/-1.5dB max over full band; +/-0.5dB max over any 40MHz			
Gain Stability	+/-1.5dB over full temperature range			
Gain Control	20dB min dynamic range			
External Reference Frequency	10MHz multiplexed with IF In			
External Reference Required Phase Noise	-130dBc/Hz @ 100Hz -140dBc/Hz @ 1kHz -150dBc/Hz @ 10kHz -155dBc/Hz @ 100kHz			
Up-Converter Phase Noise	-70dBc/Hz @ 100Hz -80dBc/Hz @ 1kHz -90dBc/Hz @ 10kHz -95dBc/Hz @ 100kHz -115dBc/Hz @ 1MHz			
Linearity: 2 tone IMD	-25dBc at 3dB total power back off from rated power -30dBc at 6dB total power back off from rated power			
Spectral Re-growth	-30dBc for QPSK at 1.5 x symbol rate at 3dB back off from rated power			
Noise Power Density: Transmit Band	-85dBm/Hz max			
Receive Band	-140dBm/Hz max			
Output Spurious: Non-signal related	-60dBc			
Signal related	-55dBc			
Power				
48VDC Voltage Range	36-72VDC Isolated			
28VDC Voltage Range (optional)	24-36VDC Isolated (optional)			
AC Voltage Range (optional)	90-265VAC 50-60Hz Auto-Ranging			
Power Consumption				
DCpower In (@ Psat / @ Plin)	160W typ. / 100W typ.	225W typ. / 160W typ.	280W typ. / 220W typ.	290W typ. / 230W typ.
Mechanical				
Size	14 x 15 x 9.5cms (14 x 19 x 9.5cms with External Output Circulator)			
Weight	2KG			
Cooling	Forced Air			
Operating temperature	-40°C to +55°C			
Relative Humidity	Up to 100% condensing			
Options				
Transmit Key Line	Transmit Key Line (iDirect X7 compatible)			
Low Ku-Band RF Output	12.75-13.25GHz (20W-50W Output Power Only)			
EIRP Power Indication	Using an Antenna Gain and IFL Calculation			
Interfaces				
IF Input Connector	N-type female			
RF Output Connector	WR75 grooved			
DC Power In	MS3112E12-3P			
RS485-RS232-Ethernet-SNMP	MS3112E14-19S			